

TOSHIBA



Installation Manual

Single Port Flow Selector Unit long piping model

RBM-Y1124FE

RBM-Y1804FE

RBM-Y2804FE

For commercial use

Single Port Flow Selector Unit (hereafter "Flow Selector unit")

Thank you very much for purchasing TOSHIBA Super Heat Recovery Multi (SHRM) Air conditioner. Please read this manual carefully before using your Flow Selector unit.

- When installing an indoor or outdoor unit, follow the installation manual supplied with the unit.
- To connect the Flow Selector unit to an outdoor unit with pipes, a branching joint or header is required. Choose one according to the capacity of the units.



ADOPTION OF NEW REFRIGERANT

This Super Heat Recovery Multi Air Conditioner is a new type which adopts a new refrigerant HFC (R410A) instead of the conventional refrigerant R22 in order to prevent destruction of the ozone layer. Be sure to use an indoor or outdoor unit in combination with the new refrigerant.

This appliance is not intended for use by person (including children) with reduced physical, sensory or mental capabilities, or lack of experience and knowledge, unless they have been given supervision or instruction concerning use of the appliance by a person responsible for their safety. Children should be supervised to ensure that they do not play with the appliance.

This appliance can be used by children aged from 8 years and above and persons with reduced physical, sensory or mental capabilities or lack of experience and knowledge if they have been given supervision or instruction concerning use of the appliance in a safe way and understand the hazards involved. Children shall not play with the appliance. Cleaning and user maintenance shall not be made by children without supervision.

[Explanation of indications]

Indication	Explanation
 WARNING	Indicates possibilities assumed that a danger causing a death or serious injury of the repair engineers, the third parties, and the users due to troubles of the product after work when an incorrect work has been executed.
 CAUTION	Indicates contents assumed that an injury or property damage (*) may be caused on the repair engineers, the third parties, and the users due to troubles of the product after work when an incorrect work has been executed.

CONTENTS

Accessory parts and Parts to be procured locally 2

1 PRECAUTIONS FOR SAFETY 3

2 INSTALLATION OF NEW REFRIGERANT AIR CONDITIONER 5

3 SELECTION OF INSTALLATION PLACE..... 5









4 INSTALLATION OF FLOW SELECTOR UNIT..... 6

5 REFRIGERANT PIPING..... 8

6 ELECTRICAL CONNECTION 10

Accessory parts and Parts to be procured locally

■ Accessory parts

Part name	Q'ty RBM-			Shape	Usage
	Y1124FE	Y1804FE	Y2804FE		
Installation Manual	1	1	1	This manual	This manual for installer. (For other languages that do not appear in this Installation Manual, Please refer to the enclosed CD-ROM.)
CD-ROM	1	1	1	-	(For other languages Installation Manual, please refer to the enclosed CD-R.)
Heat insulating pipe	∅ 63	-	-	2	 For indoor unit side gas pipe and outdoor unit side discharge gas pipe connecting sections of Y2804FE
	∅ 55	3	3	1	 For indoor unit side gas pipe and outdoor unit side suction and discharge gas pipe connecting sections of Y1124FE, Y1804FE For outdoor unit side discharge gas pipe connecting section of Y2804FE
	∅ 48	2	2	2	 For indoor and outdoor unit side liquid pipe connecting sections of each model
Attached pipe	1	-	-		∅9.5 - ∅6.4, connection pipe
Attached pipe	1	-	-		∅15.9 - ∅12.7, connection pipe
Attached pipe	1	-	-		∅15.9 - ∅9.5, connection pipe
Binding band (L100)	1	1	1		For fixing clamp filters
Clamp filter	1	1	1		For reducing electrical noise of communication wires
Cable clamp	2	2	2		For fixing indoor unit communication cable and power supply cable
Washer	6	6	6	M10 × ∅34	For hanging the unit

1 PRECAUTIONS FOR SAFETY

3

- Ensure that all Local, National and International regulations are satisfied.
- Read this “PRECAUTIONS FOR SAFETY” carefully before Installation.
- The precautions described below include the important items regarding safety. Observe them without fail.
- After the installation work, perform a trial operation to check for any problem.
Follow the Owner’s Manual to explain how to use and maintain the unit to the customer.
- Turn off the main power supply switch (or breaker) before the unit maintenance.
- Ask the customer to keep the Installation Manual and explain the customer in detail of this installation completion state.

WARNING

- **Ask an authorized dealer or qualified installation professional to install/maintain the air conditioner.**
Inappropriate installation may result in water leakage, electric shock or fire.
- **Turn off the main power supply switch or breaker before attempting any electrical work.**
Make sure all power switches are off. Failure to do so may cause electric shock.
- **Connect the connecting wire correctly.**
If the connecting wire is connected in a wrong way, electric parts may be damaged.
- **When moving the air conditioner for the installation into another place, be very careful not to enter any gaseous matter other than the specified refrigerant into the refrigeration cycle.**
If air or any other gas is mixed in the refrigerant, the gas pressure in the refrigeration cycle becomes abnormally high and it as a result causes pipe burst and injuries on persons.

- **Do not modify this unit by removing any of the safety guards or by by-passing any of the safety interlock switches.**
- **Exposure of unit to water or other moisture before installation may cause a short-circuit of electrical parts.**
Do not store it in a wet basement or expose to rain or water.
- **After unpacking the unit, examine it carefully if there is possible damage.**
- **Do not install in a place that might increase the vibration of the unit.**
- **To avoid personal injury (with sharp edges), be careful when handling parts.**
- **Perform installation work properly according to the Installation Manual.**
Inappropriate installation may result in water leakage, electric shock or fire.
- **When the air conditioner is installed in a small room, provide appropriate measures to ensure that the concentration of refrigerant leakage occur in the room does not exceed the critical level.**
- **Install the air conditioner securely in a location where the base can sustain the weight adequately.**
- **Perform the specified installation work to guard against an earthquake.**
If the air conditioner is not installed appropriately, accidents may occur due to the falling unit.
- **If refrigerant gas has leaked during the installation work, ventilate the room immediately.**
If the leaked refrigerant gas comes in contact with fire, noxious gas may generate.
- **After the installation work, confirm that refrigerant gas does not leak.**
If refrigerant gas leaks into the room and flows near a fire source, such as a cooking range, noxious gas might generate.

-
- **Electrical work must be performed by a qualified electrician in accordance with the Installation Manual. Make sure the air conditioner uses an exclusive power supply.**

An insufficient power supply capacity or inappropriate installation may cause fire.

- **Use the specified wires for wiring connect the terminals securely fix.**

To prevent external forces applied to the terminals from affecting the terminals.

- **Conform to the regulations of the local electric company when wiring the power supply.**

Inappropriate grounding may cause electric shock.

- **Do not install the air conditioner in a location subject to a risk of exposure to a combustible gas.**

If a combustible gas leaks, and stays around the unit, a fire may occur.

- **This appliance is intended to be used by expert or trained users in shops, in light industry, or for commercial use by lay persons.**
-

 **CAUTION**

New Refrigerant Air Conditioner Installation

- **THIS AIR CONDITIONER ADOPTS THE NEW HFC REFRIGERANT (R410A) WHICH DOES NOT DESTROY OZONE LAYER.**

The characteristics of R410A refrigerant are ; easy to absorb water, oxidizing membrane or oil, and its pressure is approx. 1.6 times higher than that of refrigerant R22. Accompanied with the new refrigerant, refrigerating oil has also been changed. Therefore, during installation work, be sure that water, dust, former refrigerant, or refrigerating oil does not enter the refrigerating cycle.

To prevent charging an incorrect refrigerant and refrigerating oil, the sizes of connecting sections of charging port of the main unit and installation tools are changed from those for the conventional refrigerant.

Accordingly the exclusive tools are required for the new refrigerant (R410A).

For connecting pipes, use new and clean piping designed for R410A, and please care so that water or dust does not enter. Moreover, do not use the existing piping because there are problems with pressure-resistance force and impurity in it.

2 INSTALLATION OF NEW REFRIGERANT AIR CONDITIONER

5

This air conditioner adopts the new HFC refrigerant (R410A) which does not deplete the ozone layer.

- R410A refrigerant is apt to be affected by impurity such as water, oxidizing membrane, or oils because the pressure of R410A refrigerant is higher than that of the former refrigerant by approx. 1.6 times. Accompanied with adoption of the new refrigerant, refrigerating oil has been also changed. Therefore pay attention so that water, dust, former refrigerant, or refrigerating oil does not enter into the refrigerating cycle of the new refrigerant air conditioner during installation work.
- To prevent from mixing of refrigerant or refrigerating oil, the size of charge port of the main unit or connecting section of installation tool differs from that of the air conditioner for the former refrigerant. Accordingly the exclusive tools are required for the new refrigerant (R410A) as shown below.
- For connecting pipes, use the new and clean piping materials so that water or dust does not enter.

Required tools and cautions on handling

It is necessary to prepare the tools and parts as described below for the installation work.

The tools and parts which will be newly prepared in the following items should be restricted to the exclusive use.

Explanation of symbols

- : Newly prepared (It is necessary to use it properly exclusive to R410A separated from those for R22 or R407C.)
- : Former tool is available.

Used tools	Usage	Proper use of tools/parts
Gauge manifold	Vacuuming or charging of refrigerant and operation check	● Newly prepared, Exclusive to R410A
Charging hose		● Newly prepared, Exclusive to R410A
Gas leak detector	Checks gas leak	● Newly prepared
Vacuum pump	Vacuum drying	Usable if a counter-flow preventive adapter is attached
Vacuum pump with counter-flow preventive adapter	Vacuum drying	○ : R22 (Existing article)
Bender	Bending processing of pipes	○ : R22 (Existing article)
Refrigerant recovery device	Recovers refrigerant	● Exclusive to R410A
Pipe cutter	Cuts pipes	○ : R22 (Existing article)
Refrigerant cylinder	Charges refrigerant	● Exclusive to R410A ID : Refrigerant name entered
Brazing machine/ Nitrogen gas cylinder	Brazing of pipes	○ : R22 (Existing article)
Refrigerant charging balance	Charges refrigerant	○ : R22 (Existing article)

Refrigerant piping

- Piping material used for the conventional refrigerant cannot be used.
- Use copper pipe with 0.8mm or more thickness for Ø6.4, Ø9.5, Ø12.7mm.
Use copper pipe with 1.0mm or more thickness for Ø15.9mm, Ø19.1mm, Ø22.2mm.
- Use clean and new pipes for the refrigerant pipes and perform piping work so that water or dust does not contaminate the refrigerant.

3 SELECTION OF INSTALLATION PLACE



Do not install the air conditioner at place where combustible gas may leak.

If gas leaks and is collected at surrounding the unit, the production of fire may be caused.

Cautions for Installation at a Place with the Quiet Background Sound

As the Flow Selector unit incorporates the solenoid valve, the refrigerant sound or the operating sound of the solenoid valve such as "Bushuu..." generates when exchanging between cooling and heating mode and during defrost operation. Therefore, avoid installing the unit at a place with quiet background sound as follows.

- (1) Rooms with quiet background sound such as bedroom, hospital, or room in a hotel.
- (2) Rooms which have no ceiling and a fabric does not block the residence space from the Flow Selector unit.
- (3) Rooms which have opening port at the ceiling.

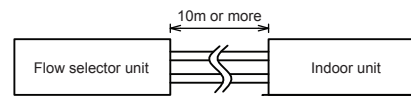

When installing the unit at the above places, separate the unit from the indoor unit (more than 10 m) and install the unit at a place so that sound does not transmit into the room such as in the corridor ceiling.

And take sound proof measure, such as covering around the Flow Selector unit with the sound proofing materials.

Upon customer's approval, install the air conditioner at a place where satisfies the following conditions.

- Place where it can be installed horizontally.
- Place which can reserve a service space for safe maintenance or check.
- Place where there is no problem even if the drained water flows.

Apply electric insulation between metal section of the building and metal section of the air conditioner in conformance with the Local Regulation.

Avoid the following places.

- Salty place (seaside area) or place with much gas sulfide (hot spring area)
(If selecting such a place, a special maintenance is required.)
- Place where oil (including machine oil), steam, oil smoke or corrosive gas generates.
- Place where a device generating high frequency (inverter, non-utility generator, medical apparatus, or communication equipment) is set. (A bad influence may generate by malfunction of the air conditioner, control trouble, or noise for such equipment.)

4 INSTALLATION OF FLOW SELECTOR UNIT

■ Installation under high-humidity atmosphere

In some cases including the rainy season, especially inside of the ceiling may become high-humidity atmosphere (dew-point temperature: 23 °C or higher).

1. Installation to inside of the ceiling with tiles on the roof
 2. Installation to inside of the ceiling with slated roof
 3. Installation to a place where inside of the ceiling is used for pathway to intake the fresh air
 4. Installation to a kitchen
- In the above cases, additionally attach the heat insulator to all positions of the air conditioner, which come to contact with the high-humidity atmosphere. In this case, arrange the side plate (Check port) so that it is easily removed.

[Reference]	Condensation test conditions
	Indoor side: 27 °C dry bulb temperature
	24 °C wet bulb temperature
	Air volume: Low air volume, operation time 4 hours

■ Installation and service space

- Reserve sufficient space required for installation or service work.
- Make space for installation and service. (Make space to the electrical parts box cover side for service.)
- When installing the unit inside the ceiling, be sure to create a check port. The check port is required when the unit is installed and serviced.
- Keep a clearance of 100 mm or more between the top panel of the unit and the ceiling.
- The length of a connection pipe to the indoor unit should be 50m or less.

<Installation space>

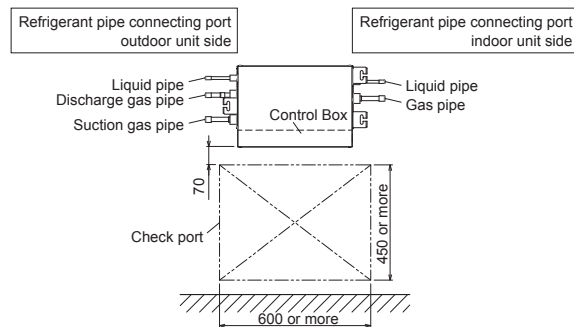

(Unit : mm)

When attached pipes are used

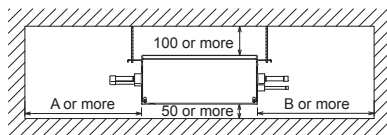

RBM-***	A	B
Y1124FE/Y1804FE	250	250 (*)
Y2804FE	400	400

(*) In case of using the attached pipe (accessory) ;
350 mm (for Y1124FE)

⚠ WARNING

Install the unit securely in the place to sufficiently withstand the weight of the unit.
If the foundation is not sturdy enough, the unit may fall and cause personal injury.

Perform a specified installation work to guard against earthquake.
Improper installation may cause the unit to fall.

REQUIREMENT

Strictly comply with the following rules to prevent damage of the Flow Selector unit and human injury.

- Do not put a heavy article on the Flow Selector unit or let a person get on it. (Even units are packaged)
- Carry in the Flow Selector unit as it is packaged if possible. If carrying in the Flow Selector unit unpacked by necessity, use buffering cloth or other material to not damage the Flow Selector unit.
- To move the Flow Selector unit, hold the hooking brackets (3 positions) only. Do not apply force to the other parts (refrigerant pipe, drain pan, foamed parts, resin parts or other parts).
- Carry the package by two or more persons, and do not bundle it with plastic band at positions other than specified.

■ Installation of hanging bolt

- Consider the piping / wiring before the unit is hung to determine the location of the Flow Selector unit installation and orientation.
- After the location of the Flow Selector unit installation has been determined, install hanging bolts.
- For the dimensions of the hanging bolt pitches, refer to the external view.
- When a ceiling already exists, lay the drain pipe, refrigerant pipe, control wires, and remote controller wires to their connection locations before hanging the Flow Selector unit.

Procure hanging bolts washer and nuts for installing the Flow Selector unit (these are not supplied).

Hanging bolt	M10 or W3/8	3 pieces
Nut	M10 or W3/8	9 pieces

Installation of hanging bolt

Use M10 hanging bolts (3 pcs, locally procured).
 Matching to the existing structure, set pitch according to size in the unit external view as shown below.

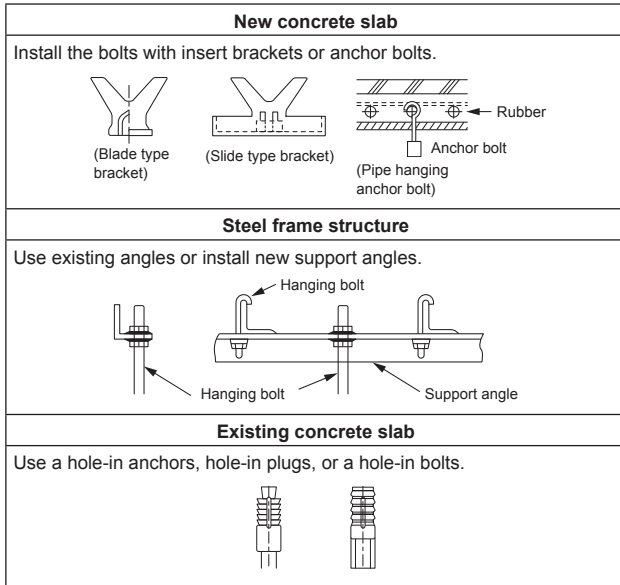

Installation of Flow Selector unit

Treatment of ceiling

The ceiling differs according to structure of building.
 For details, consult your constructor or interior finish contractor.
 In the process after the ceiling board has been removed, it is important to reinforce ceiling foundation (frame) and to keep horizontal level of installed ceiling correctly in order to prevent vibration of ceiling board.

- Attach the nuts and the M10 flat washers to the hanging bolt.
- Put washers at up and down of the hanging bracket of the Flow Selector unit to hang down the Flow Selector unit.
- Check that four sides are horizontal with a level gauge. (Horizontal degree: Within 5 mm)

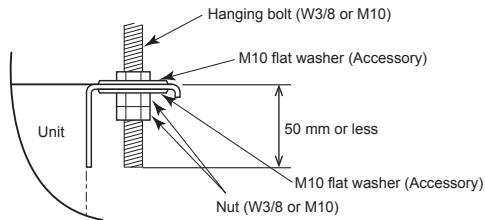

External view

(Unit:mm)

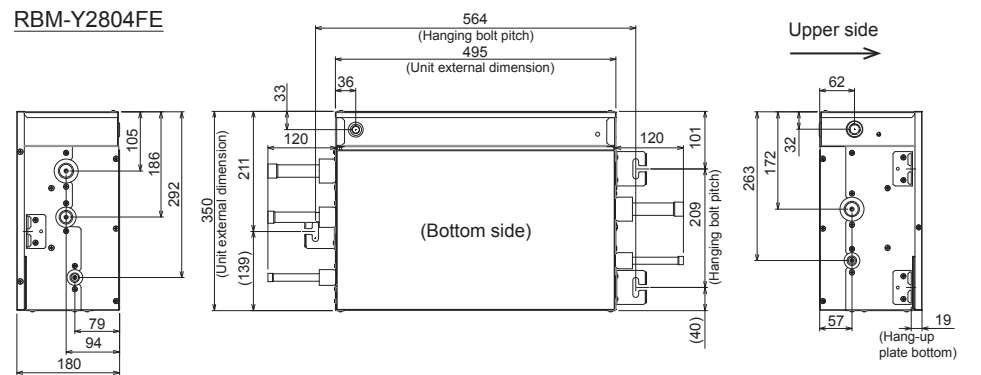
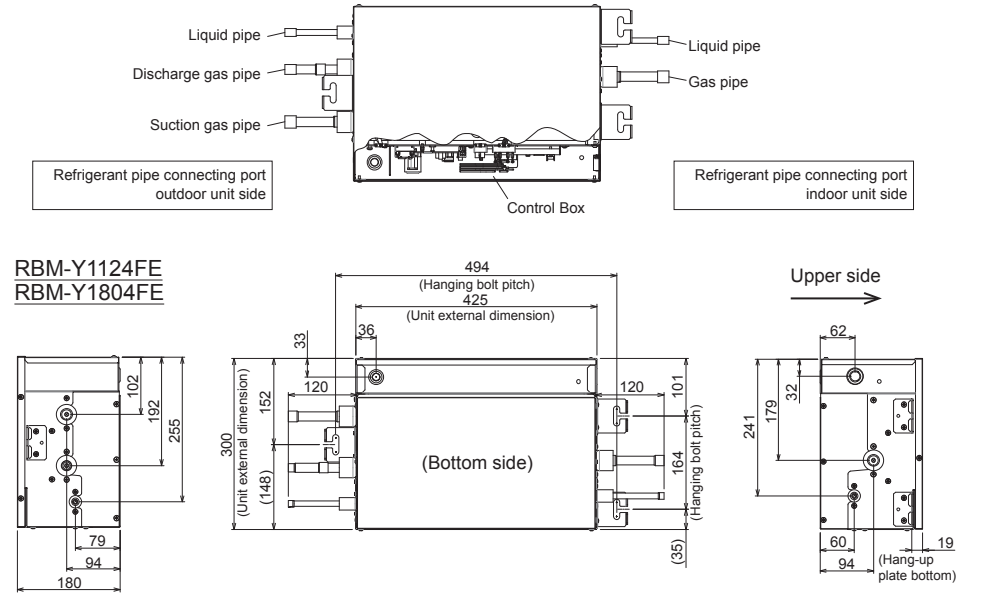

5 REFRIGERANT PIPING

⚠ WARNING

If refrigerant gas has leaked during the installation work, ventilate the room immediately.
If the leaked refrigerant gas comes in contact with fire, noxious gas may be generated.

After the installation work, confirm that refrigerant gas does not leak.
If refrigerant gas leaks into the room and flows near a fire source, such as a fan heater, cooking stove or heating unit, noxious gas may be generated.

■ Permissible pipe length and permissible height difference

The length of a connection pipe to the indoor unit should be 50 m or less.
For details, refer to the installation manual attached to the outdoor unit.

REQUIREMENT

When the refrigerant pipe is long, set the support brackets to fix the pipe at intervals of 2.5 to 3m.
If the pipe is not fixed, noise may be generated.

■ Piping dimensions

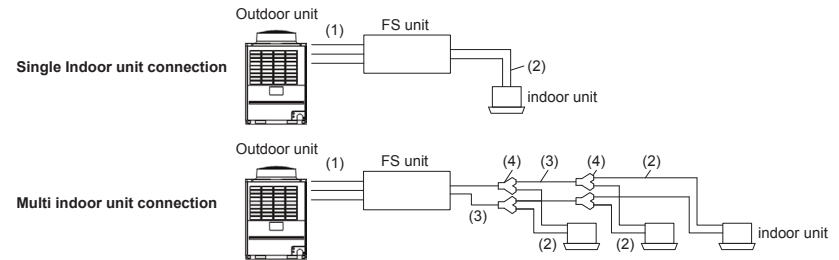

Outdoor unit side pipe size (1)

Flow Selector unit	RBM-	Y1124FE	Y1804FE	Y2804FE
Total capacity codes of indoor units at the downstream side	kW	Below 11.2	11.2 to below 18.0	18.0 to 28.0 or less
	HP	Below 4.0	4.0 to below 6.4	6.4 to 10.0 or less
Outdoor unit side pipe size (mm)	Suction gas pipe	Φ15.9	Φ15.9	Φ22.2
	Discharge gas pipe	Φ12.7	Φ12.7	Φ19.1
	Liquid pipe	Φ9.5	Φ9.5	Φ12.7

Indoor unit side pipe size (2)

Capacity rank	Equivalent to HP	Length of piping	Gas side	Liquid side
005 to 012	0.6 to 1.25	15m or less real length	Φ9.5	Φ6.4
		Exceeds 15m real length	Φ12.7	Φ9.5
015 to 018	1.7 to 2.0	15m or less real length	Φ12.7	Φ6.4
		Exceeds 15m real length	Φ15.9	Φ9.5
024 to 056	2.5 to 6.0	-	Φ15.9	Φ9.5
072 to 096	8.0 to 10.0	-	Φ22.2	Φ12.7

Indoor unit side pipe size (3)

Total capacity codes of indoor units at the downstream side		Suction gas side	Liquid side
Equivalent to capacity	Equivalent to HP		
Below 18.0	Below 6.4	Φ15.9	Φ9.5
18.0 to below 28.0	6.4 to below 10.0	Φ22.2	Φ12.7

Y-shaped branching joint (4)

Total capacity codes of indoor units at the downstream side		Y-shaped branching joint Model name
Equivalent to capacity	Equivalent to HP	
Below 18.0	Below 6.4	RBM-BY55E
18.0 to below 28.0	6.4 to below 10.0	RBM-BY105E

■ Pipe connecting process

- Connect the pipes.
- Use attached-pipe (accessory) to connect the pipe with different diameter from the pipe to Flow Selector unit (RBM-Y1124FE).

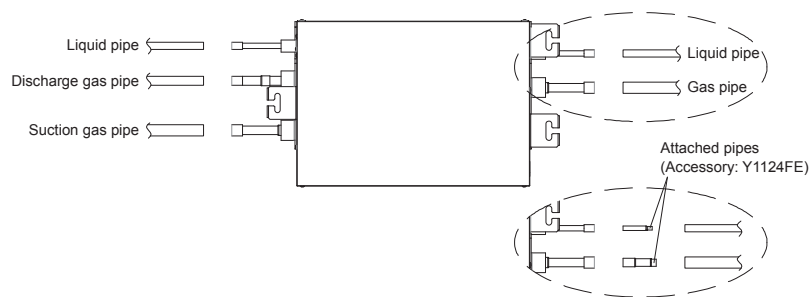

⚠ CAUTION

- * Be sure to wrap the pipe with wet cloth when applying brazing.

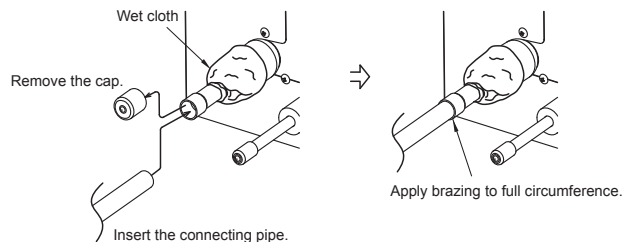

- For a brazing work of the refrigerant pipes, be sure to use nitrogen gas in order to prevent oxidation of the inside of the pipes; otherwise clogging of the refrigerating cycle due to oxidized scale may occur.
- * **Remove all flux after brazing.**

■ Airtight test/Air purge, etc.

For airtight test, air purge, addition of refrigerant, and gas leak check, follow the Installation Manual attached to the outdoor unit.

REQUIREMENT

Be sure to use the tool such as charge hose exclusive to R410A.
Do not turn on the power until the airtight test and the vacuuming have finished.
(If turning on the power, the incorporated PMV is closed fully and the period until the vacuuming finishes elongates.)

■ Open fully valves of the outdoor unit

■ Gas leak check

Check with a leak detector or soap water whether gas leaks or not, from the pipe connecting section.

REQUIREMENT

Use a leak detector manufactured exclusively for HFC refrigerant (R410A, R134a, etc.).

■ Heat insulating process

Perform heat insulating for each pipes separately.

In cooling time, temperature at both liquid and gas sides becomes lower.

Therefore, perform heat insulating process sufficiently to avoid dewing.

- For heat insulator of pipe at gas side, be sure to use one with heat-resisting temp. 120°C or more.
- Using the attached heat insulating pipe, perform heat insulating process securely for pipe connecting part of the Flow Selector units without clearance.

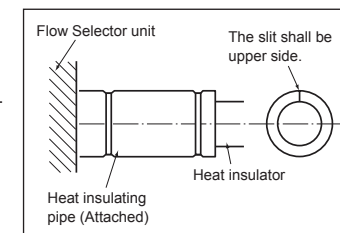

REQUIREMENT

Apply the heat insulation to the pipe connecting section of the Flow Selector unit securely up to the root without exposure of the pipe. (The pipe exposed to the outside causes water leak.)

6 ELECTRICAL CONNECTION

⚠ WARNING

- If incorrect / incomplete wiring is carried out, it will cause an electrical fire or smoke.
- Use the cord clamps attached to the product.
- Do not damage or scratch the conductive core and inner insulator of power and communication wires when peeling them.
- Use the power cord and communication wire of specified thickness, type, and protective devices required.
- Do not connect 220-240 V power to the terminal blocks (A, B) for communication wiring. (Otherwise, the system will fail.)
- Perform the electric wiring so that it does not come to contact with the high-temperature part of the pipe. The coating may melt resulting in an accident.
- Be sure to connect earth wire. (Grounding work)
Do not connect the earth wire to gas pipe, city water pipe, lightning rod, or the earth wire of telephone. Incomplete grounding causes an electric shock.
- For electric work, strictly follow to the Local Regulation in each country and the Installation Manual, and use an exclusive circuit.
Capacity shortage of power circuit or incomplete installation may an electric shock or fire.

REQUIREMENT

- For power supply wiring, strictly conform to the Local Regulation in each country.
- After connecting wires to the terminal blocks, provide a trap and fix wires with the cord clamp.
- Run the refrigerant piping line and communication wiring line in the same line.
- Do not turn on the power of the Flow Selector unit until vacuuming of the refrigerant pipes completes.

■ Power supply wire and communication wires specifications

Power supply wire and communication wires are locally procured.
For the power supply specifications, follow to the table below. If capacity is little, it is dangerous because overheat or burnout may be caused.

Power supply

- Power supply wire specification: Cable 3-core 2.5 mm², in conformity with Design 60245 IEC 57.

Power supply	220-240 V ~, 50 Hz	
Power supply switch / circuit breaker or power supply wiring / fuse rating for Flow Selector units should be selected by the accumulated total current values of the Flow Selector units.		
Power supply wiring	Below 50 m	2.5 mm ²

Communication wiring

- 2-core with non-polarity wire is used for wiring of the communication wiring.

• Wire size : 0.5 mm ² to 2.0 mm ²
• Up to 200 m total length of wiring between indoor units and Flow selector unit. (L2 + L3)
• Up to 300 m (L1 + L2 + L3)
• Up to 300 m (L1)

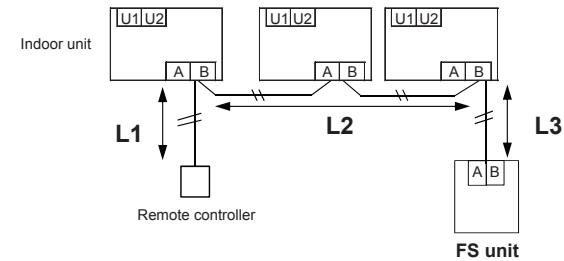

◆ Connectable number of indoor units per group control connection

The number of maximum connectable indoor units through a single remote controller is 8 units.

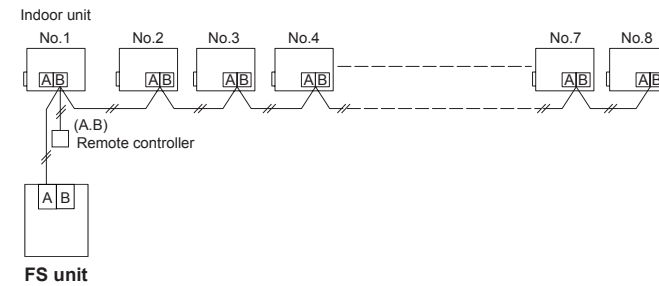

In case that two remote controllers are connected, the number of maximum connectable indoor units is 7 units.

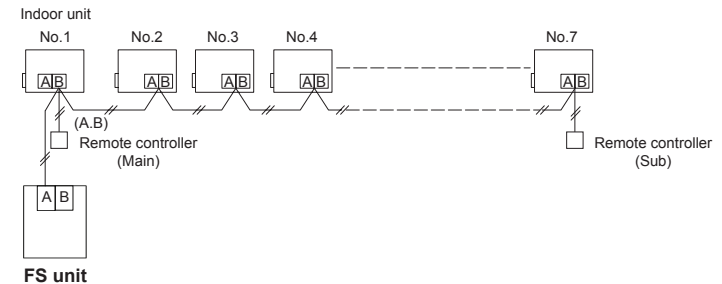

* The maximum connection number of remote controller per group is 2 pieces.

* The number of maximum connected indoor units should be less than the maximum connectable capacity of a FS unit.

⚠ CAUTION

The communication wiring and AC 220-240 V wires cannot be parallel to contact each other and cannot be stored in the same conduits. If doing so, a trouble may be caused on the control system due to noise or other factor.

■ Wire connection

REQUIREMENT

- Connect the wires matching the terminal numbers. Incorrect connection causes a trouble.
- Pass the wires through the bushing of wire connection holes of the Flow Selector unit.
- Keep a margin (Approx. 100 mm) on a wire to hang down the electrical control box at servicing.
- The low-voltage circuit is provided for the communication wires. (Do not connect the high-voltage circuit)

- 1** Loosen the cover mounting screws (2 positions) of the electrical control box, and then remove the cover.
- 2** The cable clamp (accessory) is installed in the underside of the Flow Selector unit.
- 3** Connect the power supply wire and communication wire to the terminal blocks of the electrical control box.
- 4** Tighten screws of the terminal block securely, and fix the wires with cord clamp attached to the electrical control box. (Do not apply tension to the connecting section of the terminal block.)
- 5** Mount the cover of the electrical control box so that it does not pinch the wires.

▼ Connecting power supply wire and communication wires

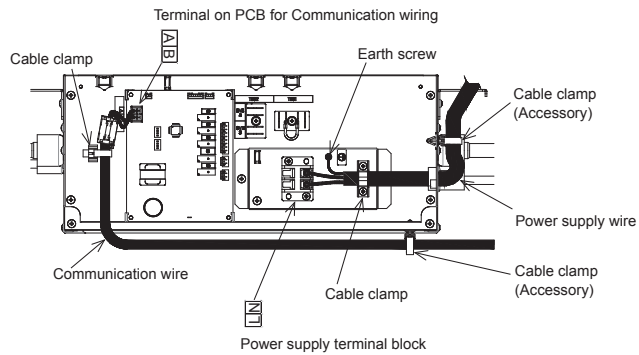

For communication wire, attach the Clamp filter (accessory) as the picture below.

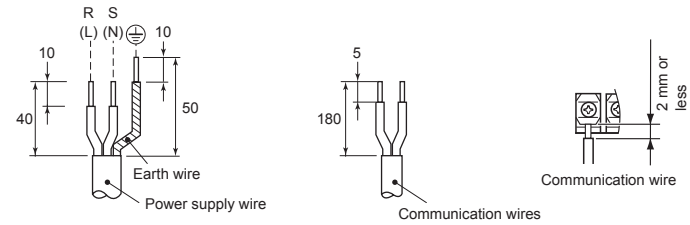
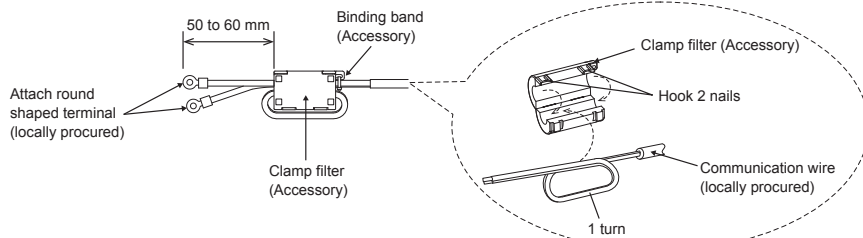

See the figure on the left for connecting wires to the terminal.

Communication wiring

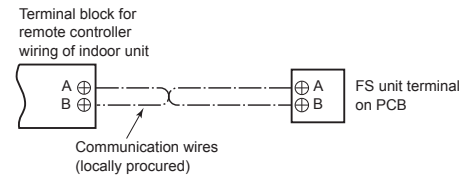

■ System wiring diagram

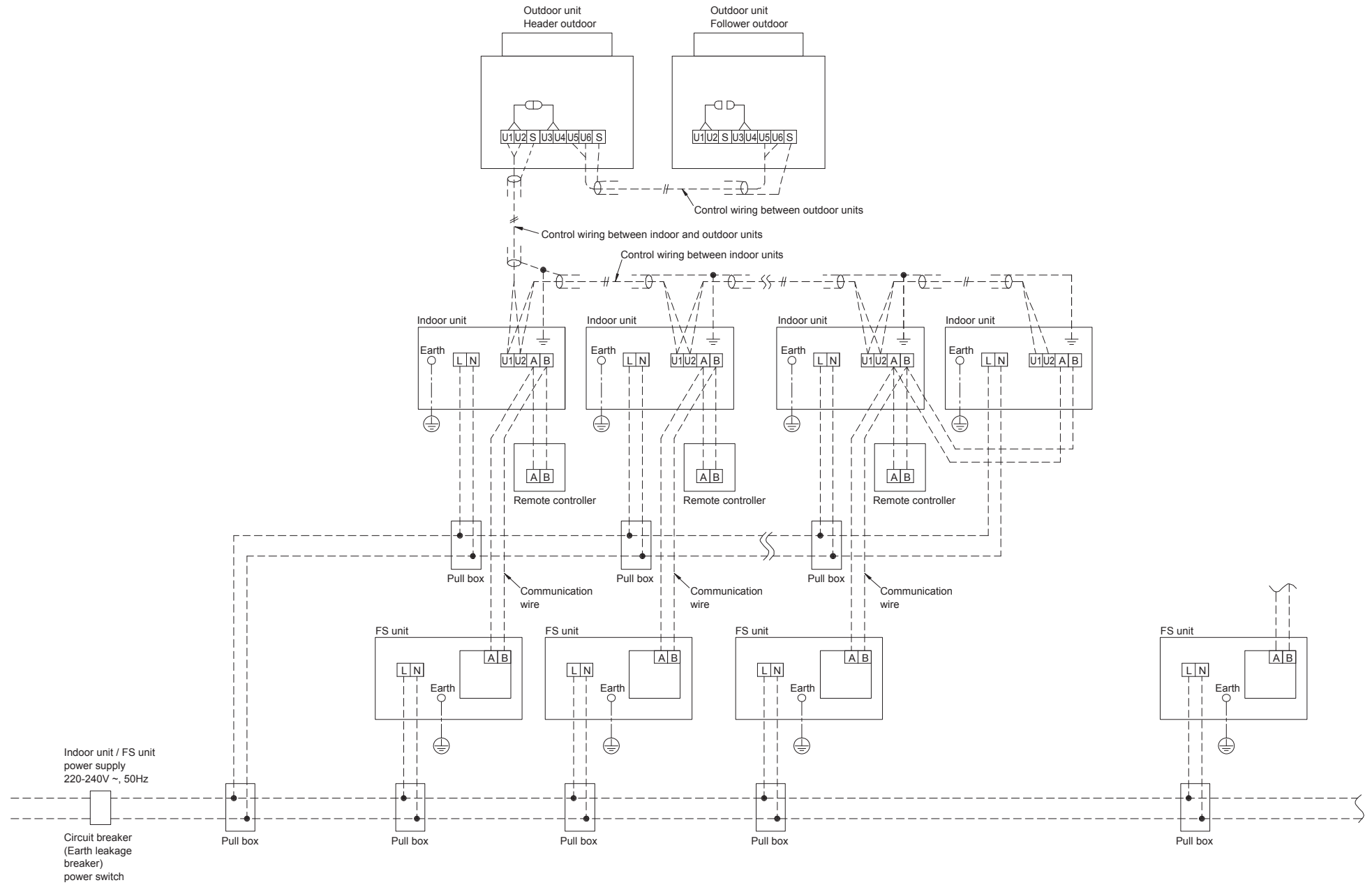

■ Setting when connecting indoor units to FS unit

◆ Caution to connection of indoor unit

When connecting the indoor units to FS unit, it is necessary to set up the CODE No..

Be sure to set up the CODE No. after set up of address.

- When connecting the indoor units to FS unit, group control and individual control are available.

[0E] : Group setting

- 0 : Individual (Factory default)
- 1 : Group

[14] : Group address setting

- 0 : Individual (Factory default)
- 1 : Header
- 2 : Follower

[FE] : Branching system address (1~64)

- Should not be duplicate in one system
- Factory default : 99

[FD] : Priority operation mode

- 0 : Heating prioritized (Factory default)
- 1 : Cooling prioritized (The cooling is prioritized even if setting only one unit in one branching)

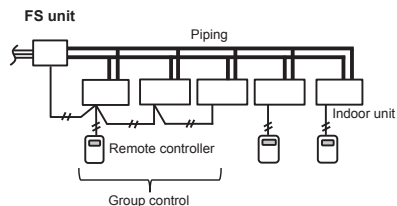

◆ How to set up CODE No. [0E]

It is necessary to set up in case of the group control.

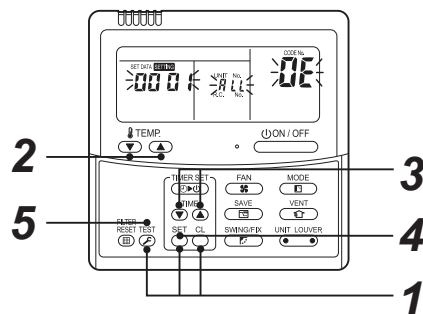

1 Push and hold the SET, CL, and TEST buttons at the same time for more than 4 seconds.

- ALL is displayed in the UNIT No. window.
- In this time, the fans of all the indoor units in the group control start the fan operation.

2 Using the set temperature buttons (▼) / (▲), select the CODE No. " 0E ".

3 Change SET DATA to " 0 / " by the timer buttons (▼) / (▲).

4 Push SET button.

5 Push TEST button. Then the setup finished.

◆ How to set up CODE No. [FE]

In cases other than connecting with one indoor unit or one group, it is necessary to set up.

- As for both single port type and multi port type, set up CODE No. "FE" in one branching within the range of 1~64.

This CODE No. should not be duplicate in one system.

◆ How to set up CODE No. [FD]

In cases other than connecting with one indoor unit or one group, it is necessary to set up.

- 0 : Heating prioritized (Factory default)
- 1 : Cooling prioritized

▼ Case that FE/FD setting is not necessary

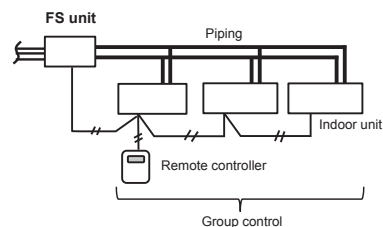

▼ Case that FE/FD setting is necessary

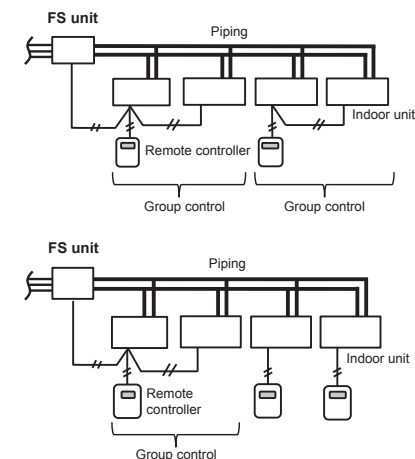

◆ [Set up example]

< In case of connecting one indoor unit >

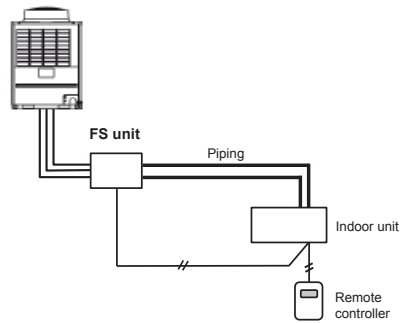

[0E] : It is not necessary to set up
 [14] : It is not necessary to set up
 [FE] : It is not necessary to set up
 [FD] : It is not necessary to set up

< In case of connecting one group operation of indoor units >

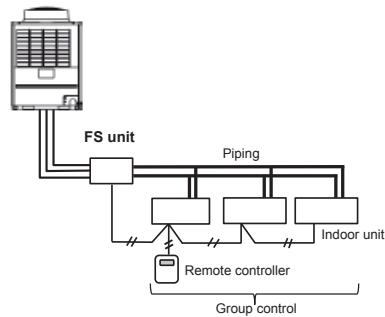

[0E] : 1 1 1
 [14] : 1 2 2
 [FE] : It is not necessary to set up
 [FD] : It is not necessary to set up

< In case of connecting two group operations of indoor units >

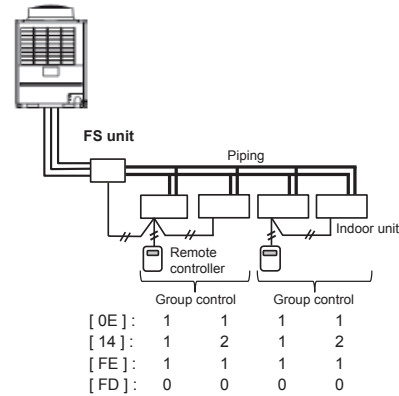

[0E] : 1 1 1 1
 [14] : 1 2 1 2
 [FE] : 1 1 1 1
 [FD] : 0 0 0 0

< In case of connecting one group operation of indoor units and two indoor units >

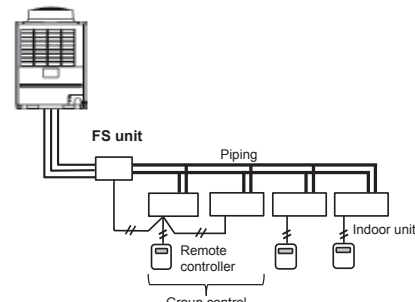

[0E] : 1 1 0 0
 [14] : 1 2 0 0
 [FE] : 1 1 1 1
 [FD] : 0 0 0 0

< In case of connecting four indoor units >

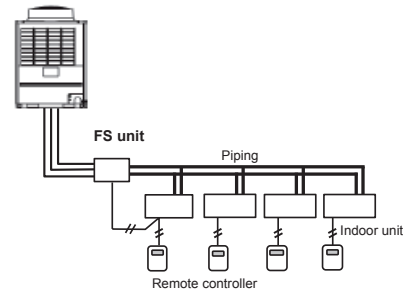

[0E] : 0 0 0 0
 [14] : 0 0 0 0
 [FE] : 1 1 1 1
 [FD] : 0 0 0 0

< In case of two or more branching system of FS units >

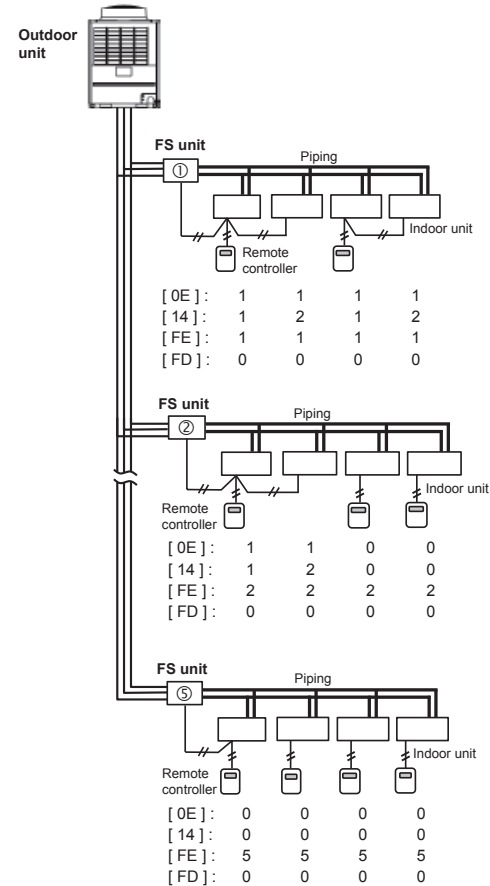

[0E] : 1 1 1 1
 [14] : 1 2 1 2
 [FE] : 1 1 1 1
 [FD] : 0 0 0 0

[0E] : 1 1 0 0
 [14] : 1 2 0 0
 [FE] : 2 2 2 2
 [FD] : 0 0 0 0

[0E] : 0 0 0 0
 [14] : 0 0 0 0
 [FE] : 5 5 5 5
 [FD] : 0 0 0 0

< Incorrect connection examples >

Incorrect

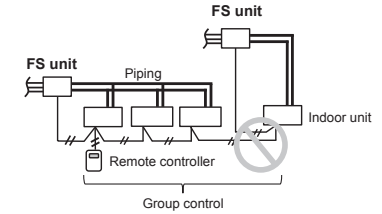

Incorrect

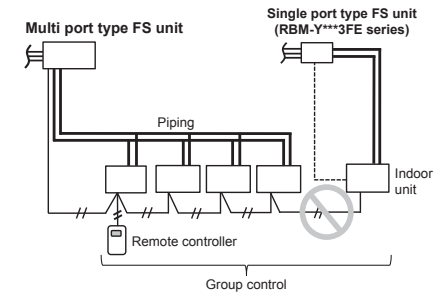

Incorrect

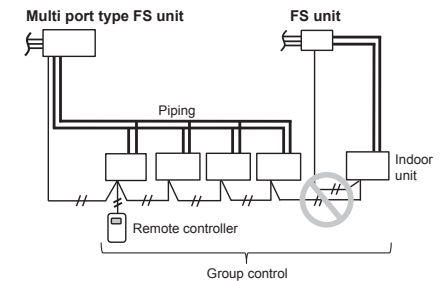

TOSHIBA CARRIER CORPORATION

336 TADEHARA, FUJI-SHI, SHIZUOKA-KEN 416-8521 JAPAN

EB99811301